

**NEW  
PRODUCT**

# TRD Manufacturing, Inc.

*A BIMBA Company*

## Heavy Duty Bench Top Presses

### **Model: BTP-501**

(FOR SINGLE PISTON  
ROD, 5" BORE,  
MF1 MOUNT  
CYLINDERS)



Heavy Duty Bench Top Press shown with 5" Bore (3) Stage Multi-Stage Cylinder and Micro-Adjust precision stroke adjustment.

### **Model: BTP-502**

(FOR 'TRA' TRIPLE  
PISTON ROD, 5" BORE,  
MF1 MOUNT  
CYLINDERS)



Heavy Duty Bench Top Press shown with 5" Bore Single-Stage Triple Rod Cylinder and Tooling Plate.

## **Features:**

---

- Heavy duty STEEL keyed & bolted construction.
- Adjustable work heights – Choose from three different built-in height settings (2" increments).
- Open work area – Allows for through feed or side feed of large parts.
- Removable, oversized ground tool plate, dowel pinned to press frame – Provides precision location of tool plate to press frame.
- Press designed to accept 5" Bore NFPA standard cylinders, Multi-Stage cylinders, or optional Triple Rod Cylinders.
- Optional External Mounted Non-Rotating Feature.
- Strokes from 1" to 6".
- Easy to Assemble or can be ordered fully assembled.
- Finish – All steel parts are Black Oxide Plated, aluminum parts are Anodized.

# BENCH TOP PRESS: HOW TO ORDER

## TO ORDER, SPECIFY:

Series, Model and Options

**BTP - 501 -**

Series		Model		Options	
BTP	Bench Top Press Frame	501	5" Bore Cylinder Mounting (Single Stage or Multi-Stage)	A	Fully Assembled (Press & Cyl.)
		502	5" Bore Triple Rod Cylinder Mounting <i>(Order Cylinder Separately)</i>	NRE	Non-Rotating External (Specify Cyl. Stroke & Rod Dia.)
				U	Un-Assembled Unit

## BENCH TOP PRESS: DIMENSIONS

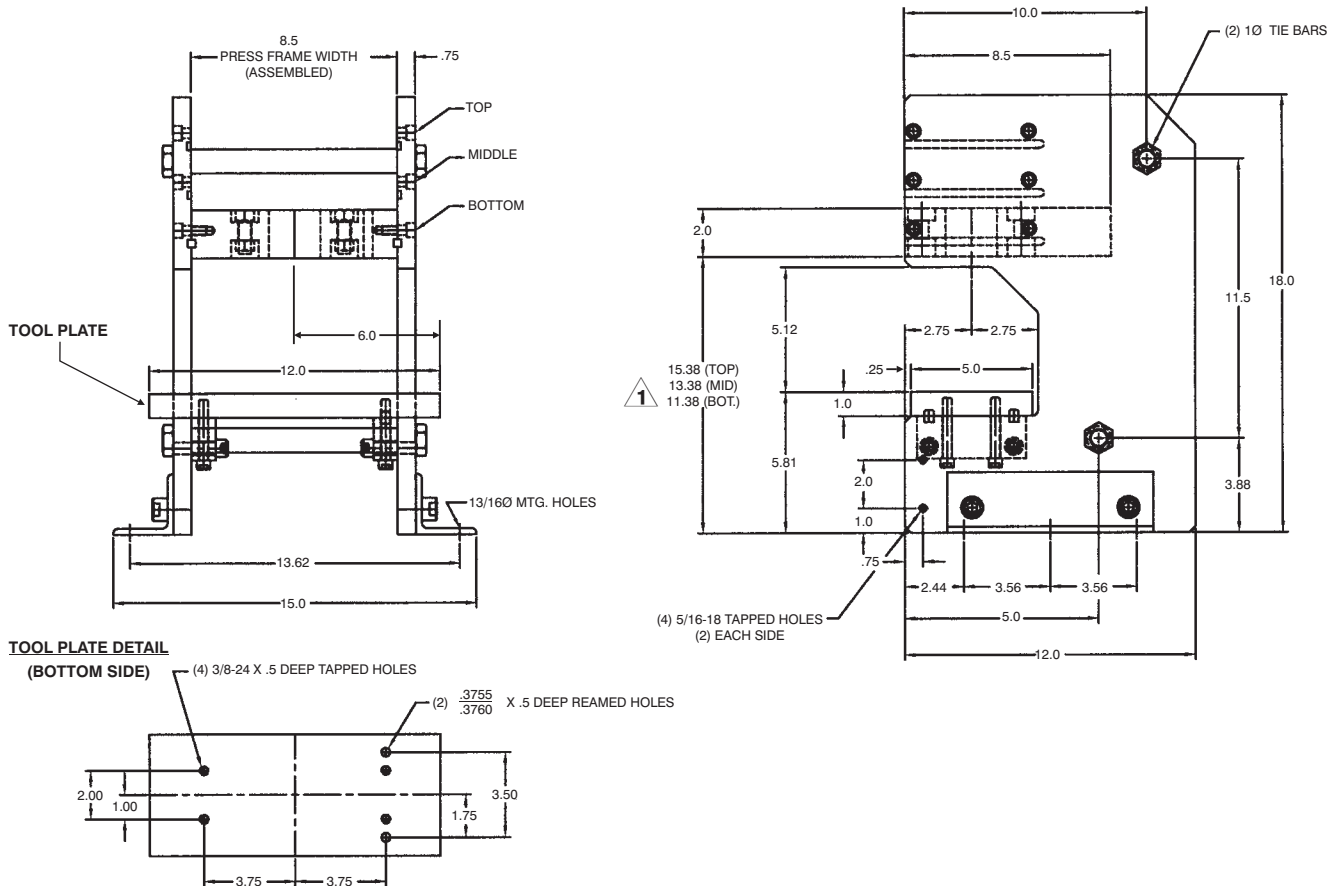

### NOTES:

1. DIMENSION REFLECTS THE PRESS TOP PLATE MOUNTED IN THE BOTTOM (LOWEST) POSITION. ADD 2." FOR MID POSITION AND 4." FOR TOP POSITION.
2. MOUNTING BRACKETS ARE REVERSEABLE AND CAN BE ASSEMBLED ON INSIDE OF PRESS FRAME TO REDUCE OVERALL WIDTH.
3. WEIGHT: 120 POUNDS (PRESS FRAME ONLY).

# BENCH TOP PRESS: TECHNICAL DATA

## CYLINDER SELECTION FORCE CHART

EXTEND FORCE									
CYLINDER	ROD DIA.	EFFECTIVE AREA EXTENDING	60 PSI	70 PSI	80 PSI	90 PSI	100 PSI	110 PSI	125 PSI
SINGLE STAGE	1" ROD DIA.	19.635	1178	1374	1570	1767	1963	2160	2454
	1 3/8" ROD DIA.	19.635	1178	1374	1570	1767	1963	2160	2454
(2) STAGE	1" ROD DIA.	38.485	2309	2693	3078	3463	3848	4233	4810
	1 3/8" ROD DIA.	37.785	2267	2644	3022	3400	3778	4156	4723
(3) STAGE	1" ROD DIA.	57.334	3440	4013	4586	5160	5733	6306	7166
	1 3/8" ROD DIA.	55.935	3356	3915	4474	5034	5593	6153	6992
(4) STAGE	1" ROD DIA.	76.184	4571	5332	6094	6856	7618	8380	9523
	1 3/8" ROD DIA.	74.085	4445	5186	5927	6667	7408	8149	9260
(5) STAGE	1" ROD DIA.	95.034	5702	6652	7602	8553	9503	10453	11879
	1 3/8" ROD DIA.	92.235	5533	6456	7379	8301	9223	10145	11529

RETRACT FORCE									
CYLINDER	ROD DIA.	EFFECTIVE AREA RETRACTING	60 PSI	70 PSI	80 PSI	90 PSI	100 PSI	110 PSI	125 PSI
SINGLE STAGE (OR MULTI-STAGE)	1" ROD DIA.	18.85	1131	1319	1508	1696	1885	2073	2356
	1 3/8" ROD DIA.	18.15	1089	1270	1452	1633	1815	1996	2268
TRIPLE ROD	1" ROD DIA.	17.279	1036	1209	1382	1555	1728	1900	2160

## PRESS FRAME DEFLECTION CHARTS

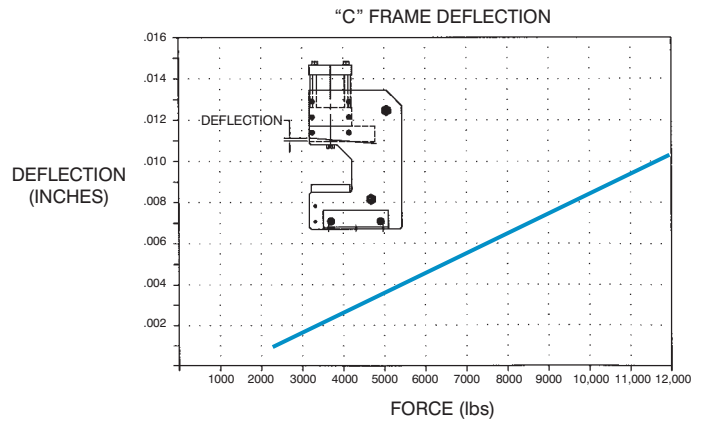
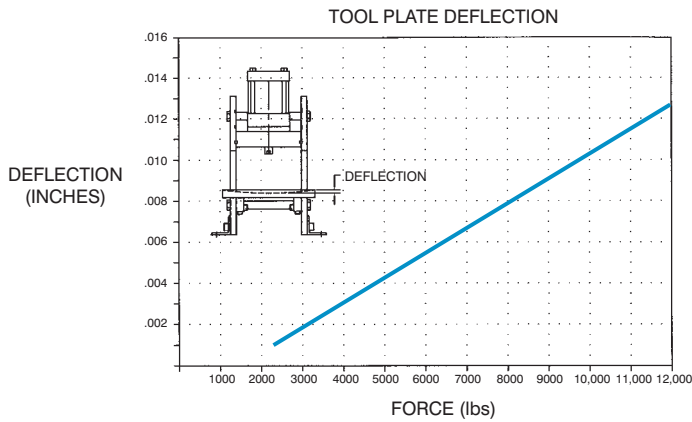

## PRESS FRAME CYLINDER SPEED CHART

Cylinder cycle rates can vary depending on air valve sizes, airline diameter and length, type of fitting, and if quick exhaust dump-valves are used.

The Speed Chart represents how fast cylinders can cycle and build pressure at each end of stroke (to simulate work being done). To maximize cylinder performance, all cycle tests were performed using 5 Cv double solenoid valves, 3/4" air hose, and quick-dump exhaust valves.

CYLINDER	CYCLES PER MINUTE
(1) STAGE-TA	263
(2) STAGE	141
(3) STAGE	125
(4) STAGE	91
(5) STAGE	77

# PRESS FRAME CYLINDER:

Choose from Single Stage, Multi-Stage, Triple-Rod (Non-Rotating with Tool Plate), or Triple-Rod Multi-Stage Press Cylinders. Double rod end styles are available on all models.

**SINGLE STAGE:** Basic single bore, double acting cylinder.

**MULTI-STAGE:** Multi-Stage cylinders are double acting and multiply the output force by supplying air to multiple pistons. The MSEP multiplies the force on the extend stroke and uses only one piston on the return stroke, saving air volume and operating costs. The MSEP/MSRP multiplies the force in both directions. Choose from 2 stage (2S), 3 stage (3S), 4 stage (4S), or 5 stage (5S) models.

**TRIPLE ROD:** A cylinder with three piston rods and a tooling plate as standard features. The 5" square tooling plate distributes the cylinder force over a large work area. Standard features also include (4) 1/2"-20 UNF tapped holes in the tooling plate that can be used to mount customer fixtures or tooling. Triple rod cylinders can be ordered as a single stage, or multi-stage (2S, 3S, 4S or 5S) models.

SINGLE STAGE OR MULTI-STAGE ROD END STYLES & OPTIONS										
<p><b>Style 3 (KK3) Female Rod End is STANDARD</b></p> <p>Other NFPA Styles can be specified (See Chart).</p> <p>Need a rod end not listed? NO PROBLEM! Each Piston Rod is made to order and does not delay shipment. Coarse (UNC) threads, Metric threads or just plain rod ends are common. Thread lengths are also made to order (Specify: "A"=Length).</p> <p>NEED SOMETHING NOT LISTED? Just send us a sketch. In most cases, quotes are turned around in one day!</p>			<p align="center"><b>PISTON ROD END STYLES</b></p>							
			<p align="center"><b>STANDARD</b></p>		<p align="center"><b>OPTIONAL</b></p>					
MM ROD DIAMETER	CP	Style 3 - Female		Style 1 - Male		Style 2 - Male		Style 4 - Male		Style 5 - Male
		KK3	A	KK1	A	KK2	A	KK4	A	KK5
1" (STANDARD)	7/8	3/4-16	1 1/8	3/4-16	1 1/8	7/8-14	1 1/8	1-14	1 1/8	NO THREAD
1 3/8" (OVERSIZE)	7/8	1-14	1 5/8	1-14	1 5/8	1 1/4-12	1 5/8	1 3/8-12	1 5/8	

## SINGLE STAGE: HOW TO ORDER

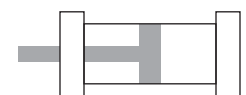

**TAP - MX3 - 5 X 1 - - - - -**

**SERIES**

TAP | 250 PSI AIR

---

**STYLE**

SINGLE ROD (LEAVE BLANK)  
D = DOUBLE ROD END (REQUIRED FOR "MA" OPTION)

---

**STROKE**

0" TO 6"  
MADE TO ORDER

**NFPA MOUNT**

**BORE**

**CUSHIONS**

NON-CUSHION (LEAVE BLANK)

H = HEAD CUSHION  
POSITION 1 STANDARD  
SPECIFY FOR POSITIONS 2, 3 OR 4 (Example = H2)

C = CAP CUSHION  
POSITION 5 STANDARD  
SPECIFY FOR POSITIONS 6, 7 OR 8 (Example = C6)

**OPTIONS**

A / O	AIR / OIL PISTON
B**	1/4" URETHANE BUMPER BOTH ENDS
BH**	1/4" URETHANE BUMPER HEAD ONLY
BC**	1/4" URETHANE BUMPER CAP ONLY
MPR	MAGNETIC PISTON FOR SWITCHES
MS	METALLIC ROD SCRAPER (BRASS)
OP	OPTIONAL PORT LOCATION
OS	OVERSIZED ROD DIAMETER (1 3/8")
TH	400 PSI HYDRAULIC, NON-SHOCK
VS	VITON® SEALS
WB	WEAR BAND ON PISTON
XX	SPECIAL VARIATION (SPECIFY)

BSR, SAE PORTS (SPECIFY SIZE)

**ROD STYLE END & MODIFICATIONS**

KK3	FEMALE ROD THREAD (LEAVE BLANK)
KK3S	STUDDED PISTON ROD (WITH KK3)
KK1	SMALL MALE ROD THREAD
KK2	LARGE MALE ROD THREAD
KK4	FULL DIAMETER MALE ROD THREAD
KK5	BLANK ROD END
"A" =	EXTENDED PISTON ROD THREAD (SPECIFY)
"C" =	EXTENDED PISTON ROD (SPECIFY)

**MICRO-ADJUST**

MA	MICRO-ADJUST
MAB	WITH NOISE DAMPENING BUMPER INSTALLED

**PORT & CUSHION POSITIONS**

- STANDARD PORT POSITIONS @ 3 AND 7 (BACK OF PRESS)
- STANDARD CUSHION POSITIONS @ 1 AND 5 (FRONT OF PRESS)
- SPECIFY NON-STANDARD LOCATIONS WHEN ORDERING

**\*\* BUMPERS ADD 1/4" PER END TO CYLINDER LENGTH**

# MULTI-STAGE: HOW TO ORDER

## (2, 3, 4 & 5 Stage Models)

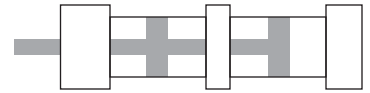

MSEP - MX3 - 5 X 1 X 2S -

SERIES	
MSEP	125 PSI AIR or HYDRAULIC, NON-SHOCK (HIGH FORCE EXTEND)
MSEP / MSRP	125 PSI AIR or HYDRAULIC, NON-SHOCK (HIGH FORCE EXTEND AND RETRACT)

NFPA MOUNT

BORE

STAGES	
2S	TWO
3S	THREE
4S	FOUR
5S	FIVE

CUSHIONS	
NON-CUSHION (LEAVE BLANK)	
H = HEAD CUSHION	
POSITION 1 STANDARD	
SPECIFY FOR POSITIONS 2, 3 OR 4 (Example = H2)	
C = CAP CUSHION (MSEP/MSRP only)	
POSITION 5 STANDARD	
SPECIFY FOR POSITIONS 6, 7 OR 8 (Example = C6)	

STYLE	
SINGLE ROD (LEAVE BLANK)	
D = DOUBLE ROD END (REQUIRED FOR "MA" OPTION)	

STROKE	
0" TO 6"	
MADE TO ORDER	

ROD STYLE END & MODIFICATIONS	
KK3	FEMALE ROD THREAD (LEAVE BLANK)
KK3S	STUDDED PISTON ROD (WITH KK3)
KK1	SMALL MALE ROD THREAD
KK2	LARGE MALE ROD THREAD
KK4	FULL DIAMETER MALE ROD THREAD
KK5	BLANK ROD END
"A"	EXTENDED PISTON ROD THREAD (SPECIFY)
"C"	EXTENDED PISTON ROD (SPECIFY)

OPTIONS	
B**	1/4" URETHANE BUMPER BOTH ENDS
BH**	1/4" URETHANE BUMPER HEAD ONLY
BC**	1/4" URETHANE BUMPER CAP ONLY
MPR*	MAGNETIC PISTON FOR SWITCHES
MS	METALLIC ROD SCRAPER (BRASS)
OP	OPTIONAL PORT LOCATION
OS	OVERSIZED ROD DIAMETER (1 3/8")
VS	VITON® SEALS
XX	SPECIAL VARIATION (SPECIFY)
BSP, SAE PORTS (SPECIFY SIZE)	

MICRO-ADJUST	
MA	MICRO-ADJUST
MAB	WITH NOISE DAMPENING BUMPER INSTALLED

\*\* BUMPERS ADD 1/4" PER END TO CYLINDER LENGTH  
\*MPR ADD 7/8" TO CYLINDER LENGTH

## How they work

**Model MSEP**

**4 Stage Shown**

**EXTENDING STROKE**

Extension-air supplied to multiple pistons

**RETRACTING STROKE**

Retraction-air supplied to one piston

**NOTE:** Cap cushion not available on MSEP

**Model MSEP/MSRP**

**2 Stage Shown**

**EXTENDING STROKE**

Extension AND Retraction-air supplied to multiple pistons

**HEAD AND CAP CUSHION AVAILABLE**

**To Order, specify:**  
"MSEP/MSRP" (as model number)

(Note: Overall lengths are increased-)

**RETRACTING STROKE**

## TRIPLE-ROD: HOW TO ORDER

### (with Tool Plate)

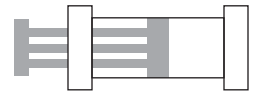

TRAP - MF1 - 5 X 1 X 2S -

NFPA MOUNT

BORE

SERIES	
TRAP	SINGLE STAGE, 200 PSI AIR
TRAP-MSE	MULTI-STAGE EXTEND, 125 PSI AIR

STAGES	
SINGLE STAGE (LEAVE BLANK)	
2S	TWO
3S	THREE
4S	FOUR
5S	FIVE

CUSHIONS	
NON-CUSHION (LEAVE BLANK)	
H = HEAD CUSHION	
POSITION 2 STANDARD	
SPECIFY FOR POSITIONS 1, OR 4 (Example = H2)	
C = CAP CUSHION (TRP only)	
POSITION 6 STANDARD	
SPECIFY FOR POSITIONS 5, OR 8 (Example = C6)	

STYLE	
SINGLE ROD (LEAVE BLANK)	
D = DOUBLE ROD END (SINGLE ROD AT CAP) (REQUIRED FOR "MA" OPTION)	

STROKE	
0" TO 6"	
MADE TO ORDER	

OPTIONS	
B**	1/4" URETHANE BUMPER BOTH ENDS
BH**	1/4" URETHANE BUMPER HEAD ONLY
BC**	1/4" URETHANE BUMPER CAP ONLY
MPR	MAGNETIC PISTON FOR SWITCHES
OP	OPTIONAL PORT LOCATION
TH	400 PSI HYDRAULIC, NON-SHOCK
VS	VITON® SEALS
XX	SPECIAL VARIATION (SPECIFY)
BSP, SAE PORTS (SPECIFY SIZE)	

MICRO-ADJUST	
MA	MICRO-ADJUST
MAB	WITH NOISE DAMPENING BUMPER INSTALLED

\*\* BUMPERS ADD 1/4" PER END TO CYLINDER LENGTH

### PORT & CUSHION POSITIONS

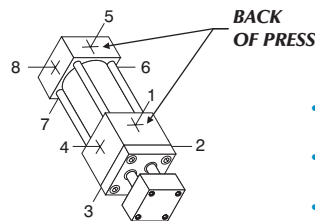
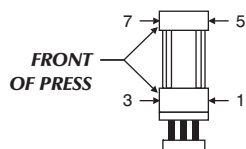

- STANDARD PORT POSITIONS @ 1 AND 5 (BACK OF PRESS)
- STANDARD CUSHION POSITIONS @ 2 AND 6 (SIDE OF PRESS)
- (NOTE: PORTS OR CUSHIONS NOT AVAILABLE AT POSITIONS 3 & 7, FRONT OF PRESS)

# PRESS FRAME CYLINDER: OPTIONS

**B** **BC** **BH** **Bumpers**

Urethane impact dampening bumpers, used when cylinder speeds do not allow for standard cushions.

**BC**=Cap Bumper **BH**=Head Bumper **B**=Head & Cap Bumper  
(Note: Each bumper adds 1/4" to cylinder length)

**D** **Double Rod**

Double rod end cylinders offer more rigidity than single piston rod cylinders. The piston rod assembly is supported and guided at each end of the cylinder with Teflon® coated cast iron rod bearings.

**Double rod end cylinders minimize piston rod end play.**

**H** **C** **Cushions**

TRD's advanced cushion design features a unique, one piece seal that is allowed to float in a precision machined groove. This type of seal design provides consistent cushion performance and maximum seal life. Oversized flow paths molded in the periphery of the seal provide "full flow" on the return stroke without the use of ball checks.

**H**=Head Cushion **C**=Cap Cushion

**MPR** **MPH** **Magnetic Piston**

Magnetic Pistons are used in conjunction with Reed and Hall Effect (solid state) Switches. (See Catalog #TRDSW-1100 for switch information).

**OS** **Oversized Rod**

**OVERSIZED PISTON ROD**      **STANDARD PISTON ROD**

OVERSIZED ROD HAS 90% MORE COMPRESSIVE LOAD CAPACITY THAN STANDARD ROD. ALSO INCREASES ROD BEARING AREA.

Recommended in applications that require press forces distributed over larger work areas.

**LINEAR TRANSDUCER READY**

Cylinder can be equipped ready to accept linear transducers (Bimba, Balluff, MTS, etc.), to provide actual position feedback throughout the entire stroke.

To order, specify "Ready for (type of transducer) at end of model number. (Note: TRD can furnish Bimba PFC transducers. Customer to provide and install all other types).

**MS** **Metallic Rod Scraper**

Aggressively scrapes the piston rod, removing foreign material such as spatter, sprays and powders. (Brass construction)

**KK3S** **Studded KK3 Rod Thread**

Offers highest fatigue resistance. A non-removable stud is inserted in a "KK3" (female rod end). Does not effect "A" Dim. (Rod thread length).

**WB** **Wear Band (On Piston O.D.)**

Teflon® composite material, provides a more durable, long life wear surface without lubrication. (Can be ordered with MPR or MPH Options.)

**Other Options Available**

- Shock Absorber (Ready)
- Longer Strokes
- Transducers for Multi-Stage Cylinders (Balluff Back Pack)
- Hollow Piston Rods (Available on Double Rod models)

**Other Models Available**

- 8" Bore TAP, MSEP 2S or 3S models - consult factory for details

**If the option you need isn't listed, just call TRD! We can accommodate most requests.**

# PRESS FRAME CYLINDER: OPTIONS

## MA *Micro-Adjust*

- Allows precise adjustment of cylinder extend stroke
- Easy to read precision scale (.001" calibration)
- Enclosed, no "pinch point" design
- Available on all cylinder models with "D" Double Rod End option
- Up to 6" stroke and adjustment\*

\*Note: The adjustment range is throughout entire stroke. Consult factory for longer stroke requirements or modifications not listed.

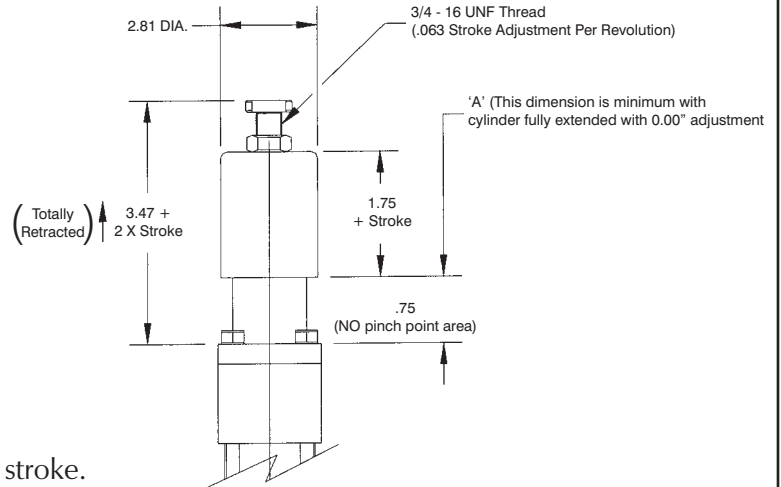

### MICRO-ADJUST SET-UP INSTRUCTIONS:

- 1) Set actuator to desired stroke
- 2) Turn stop collar until it makes contact with stop
- 3) Tighten set screw
- 4) Tighten jam nut for positive lock of stop collar

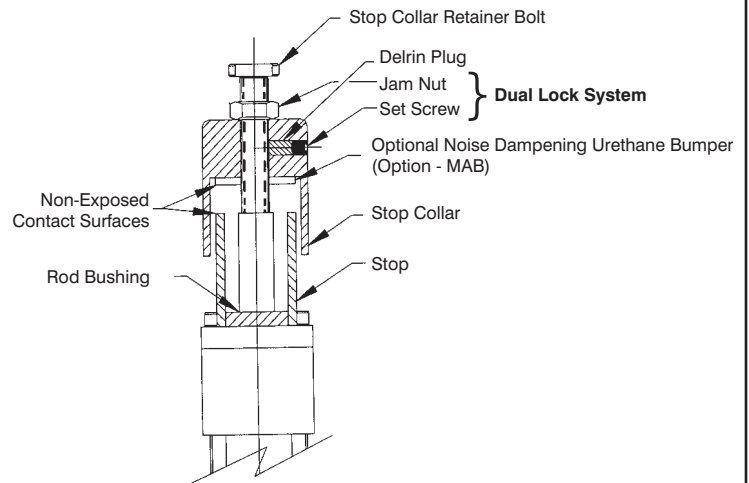

## NRE *External Non-Rotating*

The External Non-Rotating option prevents the piston rod (and any attached tooling) from rotating as the cylinder cycles.

Since the "NRE" bracket and guide rod are externally mounted, they can be added or removed for different applications. All press frames are made to accept this "add on" option.

For high torsional load applications, cylinders can be equipped with a twin guide rod internally ("NR" cylinder option).

Consult factory for details.

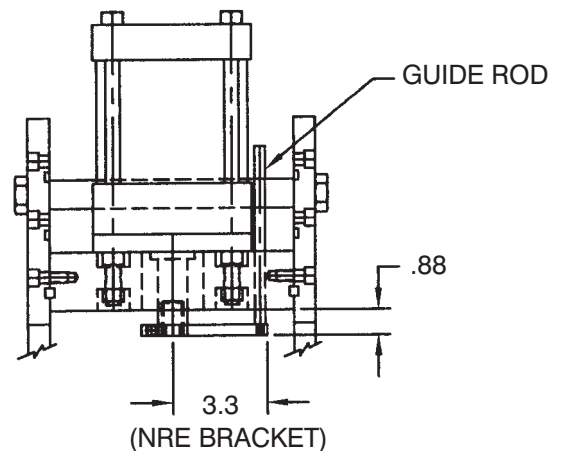

# PRESS FRAME CYLINDER: DIMENSIONS

## TAP (SINGLE STAGE)

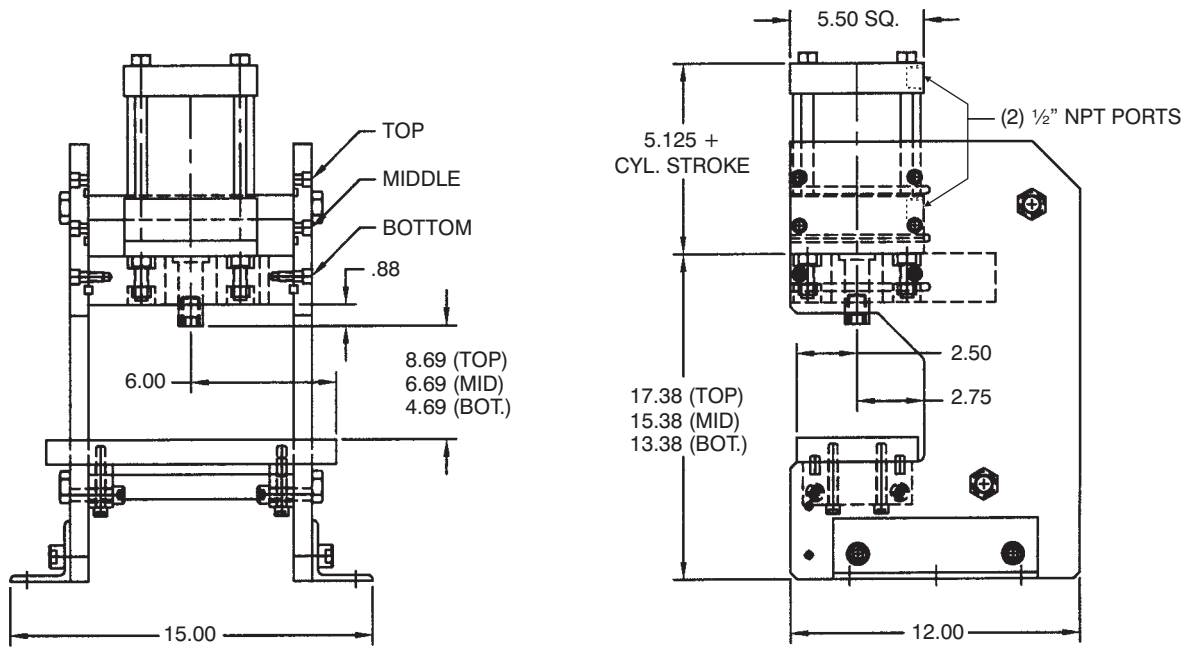

## MSEP 2S (2 STAGE)

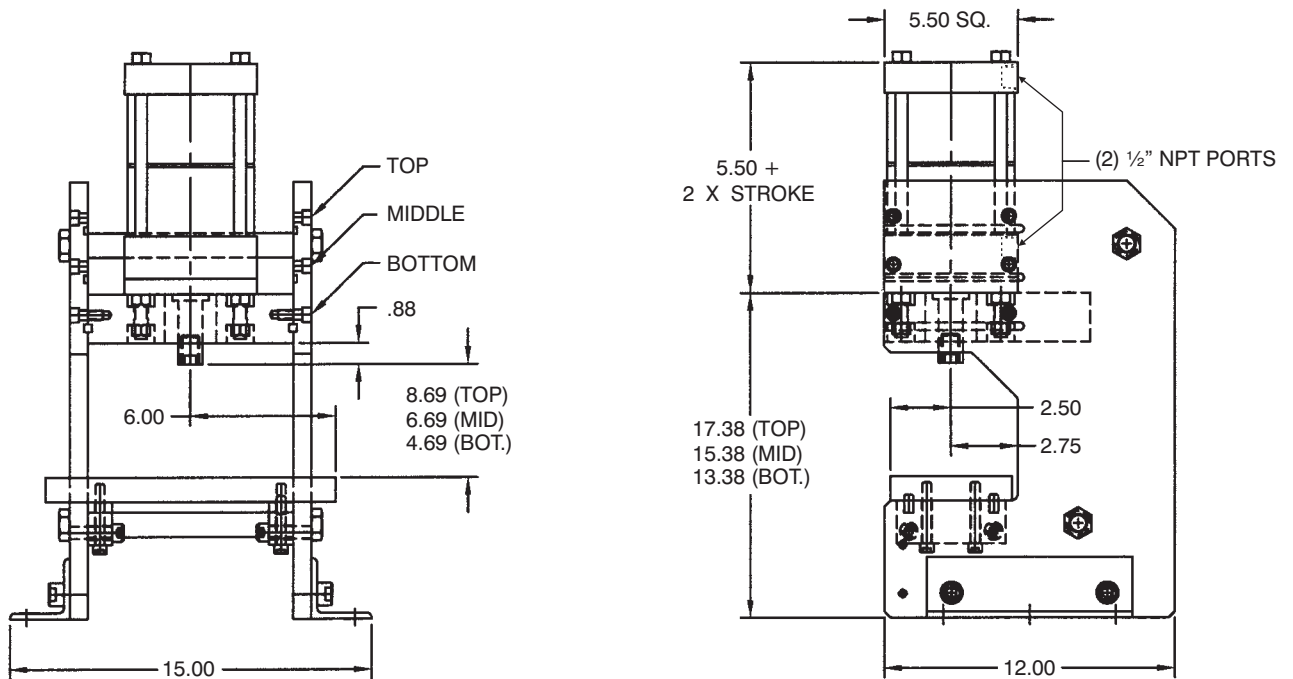

# PRESS FRAME CYLINDER: DIMENSIONS

## MSEP 3S (3 STAGE)

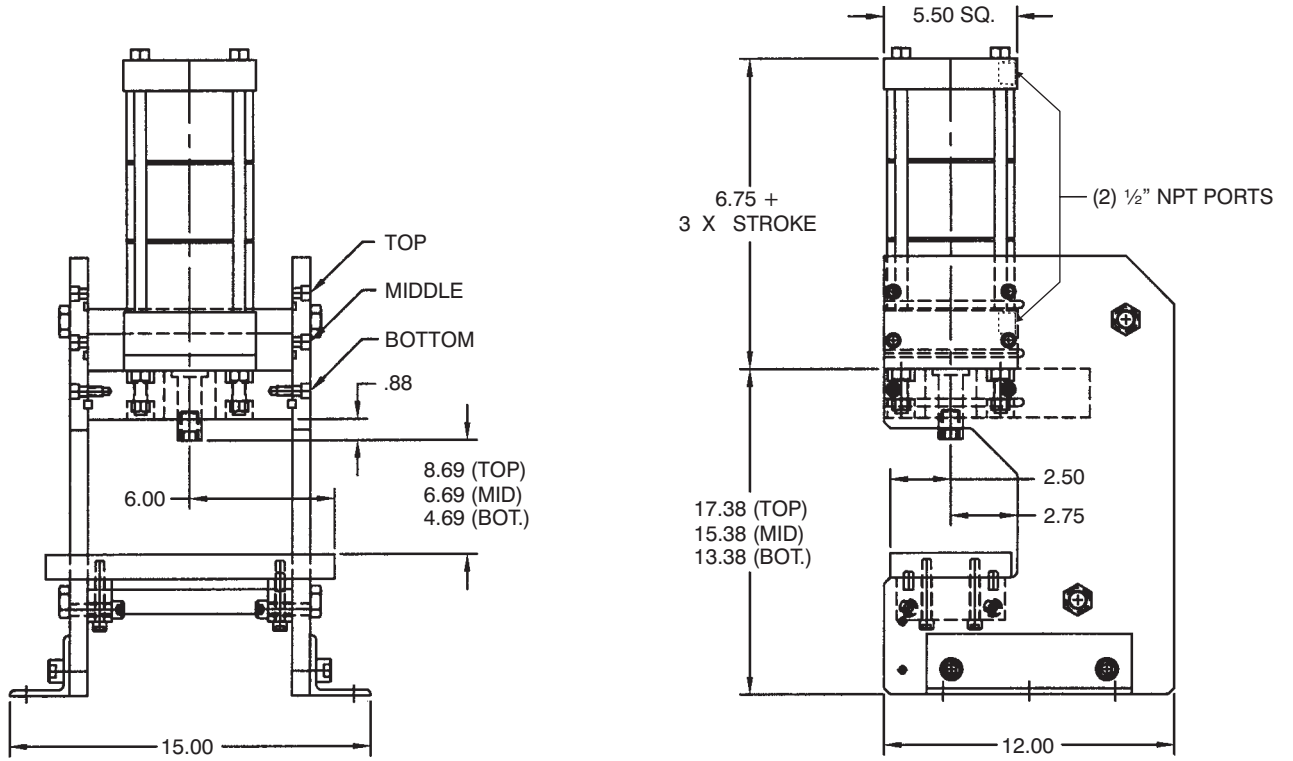

## MSEP 4S (4 STAGE)

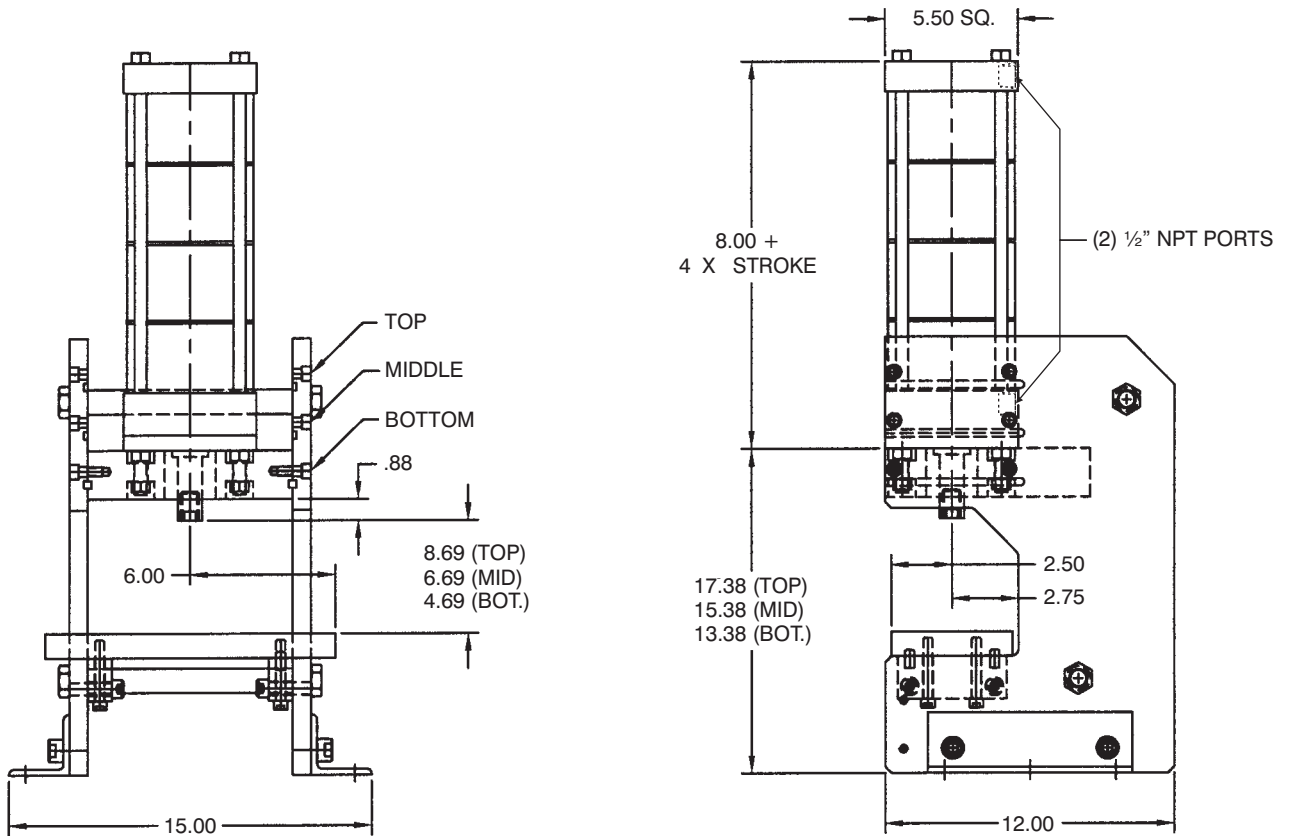

# PRESS FRAME CYLINDER: DIMENSIONS

## MSEP 5S (5 STAGE)

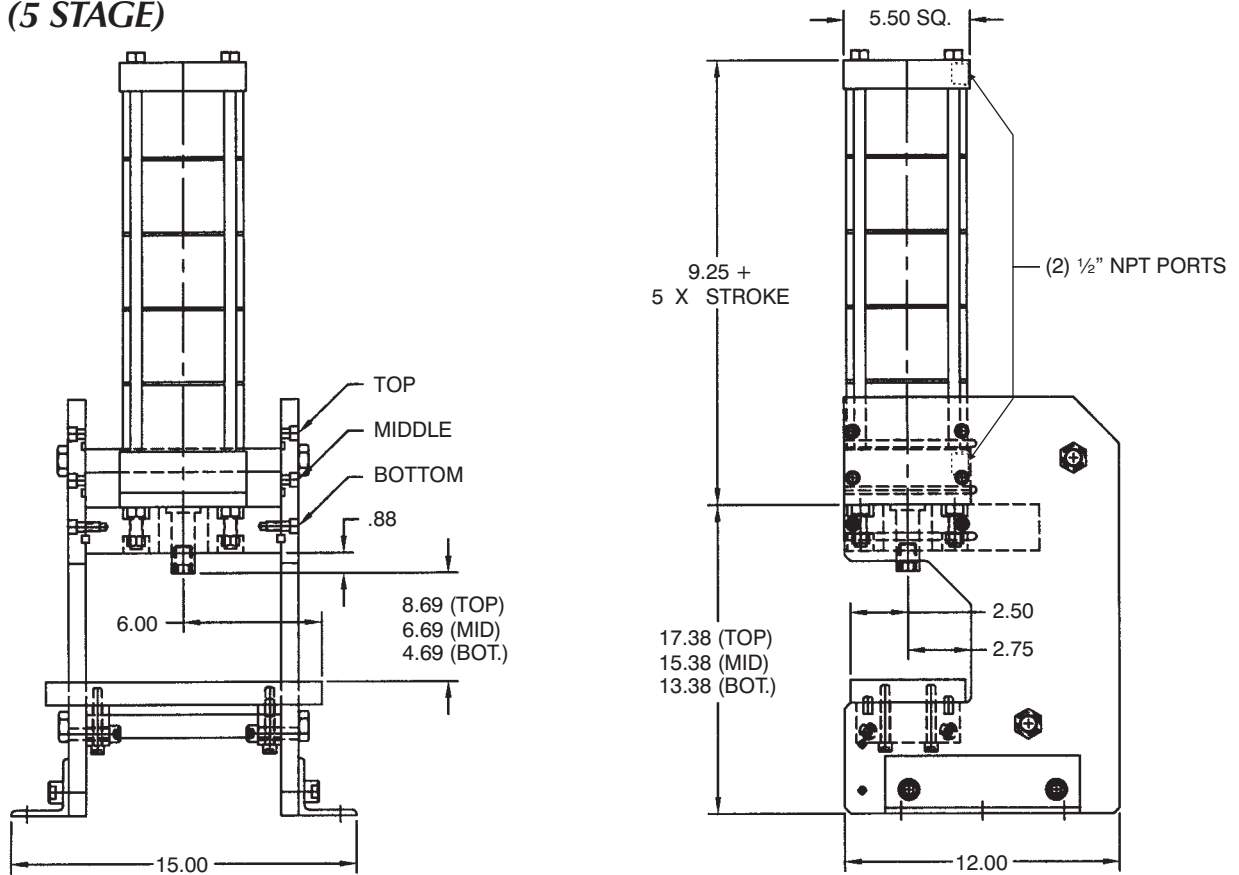

## TRP (TRIPLE ROD)

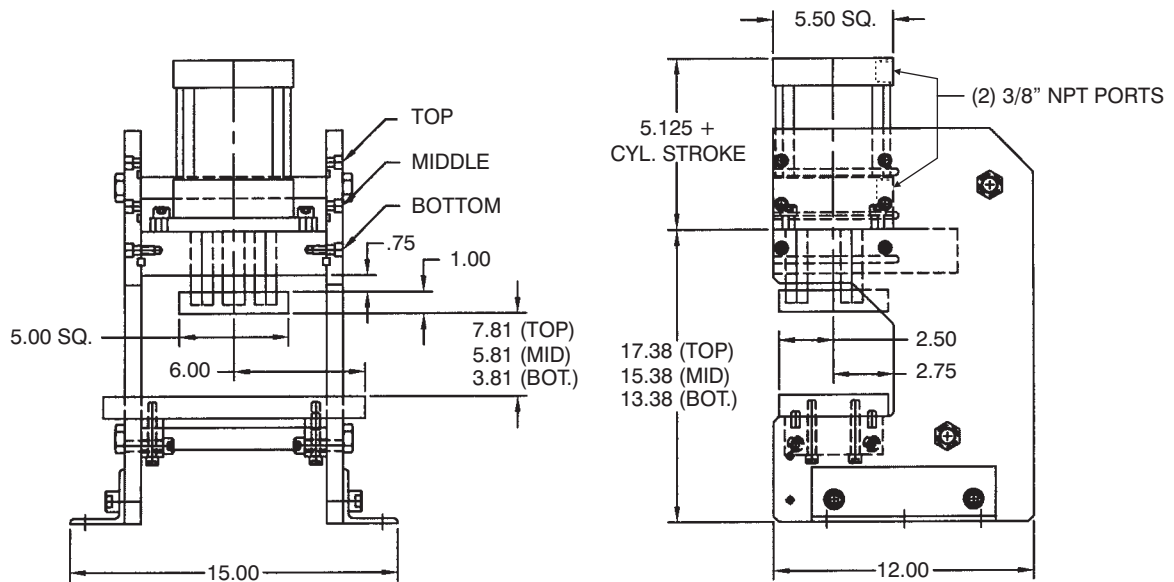

### TOOLING PLATE DETAIL

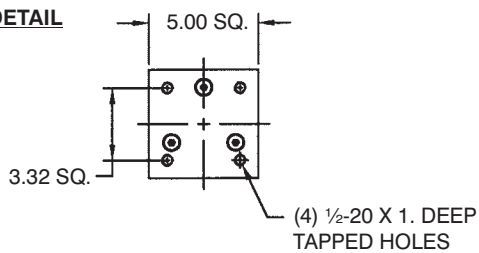

**Worldwide Distribution means there is a Professional Distributor Representative nearby – wherever you are – ready to service your needs.**

***Ask Your Local Distributor About These Other Products:***



**NFPA cylinders with continuous piston rod position sensing.**

Can be used for measuring and gauging applications.  
Available from 1½" to 8" Bore

**NFPA cylinders with Pneumatic Position Control System.**

For applications requiring accurate control of piston rod positioning in bore sizes from 1½" to 4".

*Request Catalog TRD #PFLF-1004*



**NFPA Aluminum cylinders**

Available from 1½" to 12" Bore

**NFPA Aluminum Non-Rotating cylinders**

Available from 2" to 12" Bore

**NFPA Electroless Nickel Plated cylinders**

Available from 1½" to 12" Bore

**Aluminum Multi-Stage force multiplying cylinders**

Available from 1½" to 8" Bore

*Request Catalog TRD #CAT-TRD1-0104*



**NFPA Interchangeable Stainless Steel cylinders**

Available from 1½" to 8" Bore

**Stainless Steel Non-Rotating cylinders**

Available from 2" to 8" Bore

**Stainless Steel Multi-Stage force multiplying cylinders**

Available from 1½" to 6" Bore

**Stainless Steel Air/Oil Tanks and Stainless Steel Accessories**

*Request Catalog TRD #CAT-TRDSS-704*

***TRD offers a complete range of custom solutions for your actuator needs.***

Here are a few examples of actuators developed for OEM applications:



**2½" Bore Custom (Alum.)**



**4½" Bore Custom (Steel)**



**2½"-8" Bore Spherical Brg. (Steel)**



**1½" Bore Custom (Alum.)**

# **TRD DELIVERIES** *(F.O.B. Factory)*

## SERIES

## DELIVERY SCHEDULE

BTP (501 or 502 PRESS FRAME) . . . . .	2-3 DAYS
TAP/TRAP (SINGLE STAGE PRESS CYLINDERS). . . . .	2-3 DAYS
MSEP (MULTI-STAGE PRESS CYLINDERS). . . . .	3-4 DAYS
TRAP-MSE (TRIPLE ROD MULTI-STAGE CYLINDERS). . . . .	3-4 DAYS

*STANDARD OPTIONS INCLUDED IN ABOVE DELIVERIES*

### **RUSH SERVICE**

*RUSH SERVICES ARE AVAILABLE FOR ALL TRD PRODUCTS.  
CONTACT YOUR LOCAL TRD DISTRIBUTOR FOR DETAILS.*

YOUR LOCAL DISTRIBUTOR IS:



## **TRD Manufacturing, Inc.**

*A **BIMBA** Company*

10914 N. 2ND STREET • MACHESNEY PARK, ILLINOIS 61115-1400

PHONE: (815) 654-7775 • FAX: (815) 654-0690

WEBSITE: [WWW.TRDMFG.COM](http://WWW.TRDMFG.COM) • E-MAIL: [SALES@TRDMFG.COM](mailto:SALES@TRDMFG.COM)