

# ACCESSORIES: CLEVIS, PINS & MOUNTS

## Accessories Cross Reference Chart

CYLINDER MODEL				ACCESSORIES				
BORE	ROD SIZE	ROD STYLE (KK)	ROD THREAD	ROD CLEVIS	ROD EYE	CLEVIS PIN	CLEVIS BRACKET	EYE BRACKET
1.50, 2, 2.50	.63	#1 (STANDARD) KK1	.44-20	RC437	RE437	CP500	CB500	EB500
		#2 KK2	.50-20	RC500	RE500	CP500		
	1	#1 (ST'D-OVERSIZE) KK1	.75-16	RC750	RE750	CP750		
		#4 KK4	1-14	RC1000	RE1000	CP1000		
3.25, 4, 5	1	#1 (STANDARD) KK1	.75-16	RC750	RE750	CP750	CB750	EB750
		#4 KK4	1-14	RC1000	RE1000	CP1000		
	1.38	#1 (ST'D-OVERSIZE) KK1	1-14	RC1000	RE1000	CP1000		
		#2 KK2	1.25-12	RC1250	N/A	CP1375		
6 & 8	1.38	#1 (STANDARD) KK1	1-14	RC1000	RE1000	CP1000	CB1000	EB1000
		#2 KK2	1.25-12	RC1250	N/A	CP1375		
	1.75	#1 (ST'D-OVERSIZE) KK1	1.25-12	RC1250	N/A	CP1375		
		#2 KK2	1.50-12	RC1500	N/A	CP1750		
10	1.75	#1 (STANDARD) KK1	1.25-12	RC1250	RE1250	CP1375	CB1375	EB1375
	2	#2 KK2	1.50-12	RC1500	RE1500	CP1750	CB1750	EB1750
12	2	#1 (STANDARD) KK1	1.50-12	RC1500	RE1500	CP1750	CB1750	EB1750
		#1 (STANDARD) KK1	1.50-12	RC1500	RE1500	CP1750	CB1750	EB1750

CLEVIS PIN (WITH BRIDGE PIN - STANDARD)					
PART NO.	CD	H	HP	LH	LP
CP500	.50	.63	.16	2.25	2.09
CP750	.75	.94	.16	3	2.84
CP1000	1	1.19	.20	3.50	3.31

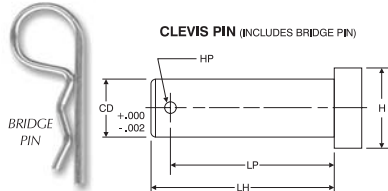

**CLEVIS PIN (INCLUDES BRIDGE PIN)**

**MATERIAL:** 1018 CRS  
**FINISH:** BLACK OXIDE

CLEVIS PIN (WITH COTTER PINS)			
PART NO.	CD	LH	LP
CP500C	.50	2.25	1.94
CP750C	.75	3	2.72
CP1000C	1	3.50	3.22
CP1375C	1.38	5	4.25
CP1750C	1.75	6	5.50
CP2000C	2	6	5.50

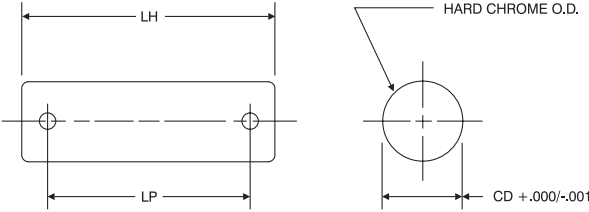

**CLEVIS PIN (INCLUDES COTTER PINS)**

**MATERIAL:** 1045 CRS  
**FINISH:** CHROME PLATED O.D.

CLEVIS PIN (WITH E-RINGS)			
PART NO.	CD	LH	LP
CP500E	.50	2.13	1.88
CP750E	.75	2.94	2.63
CP1000E	1	3.44	3.13

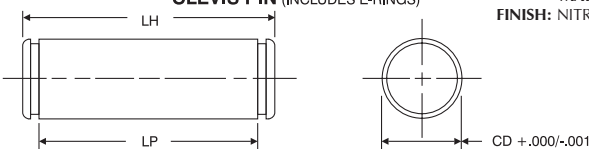

**CLEVIS PIN (INCLUDES E-RINGS)**

**MATERIAL:** 1045 CRS  
**FINISH:** NITROTECH PLATED\*

\*HARD CHROME PLATED O.D. AVAILABLE

SMALL CLEVIS PIN (WITH BRIDGE PIN)				
PART NO.	CD	HP	LH	LP
CP500CCS	.50	.16	1.38	1.25
CP750CCS	.75	.16	2	1.88

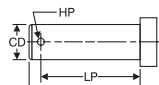

**MATERIAL:** 1018 CRS  
**FINISH:** BLACK OXIDE

**SMALL CLEVIS PIN (INCLUDES BRIDGE PIN)**

SMALL ROD CLEVIS									
PART NO.	C	CB	CD	CE	CH	CW	KK1	KK2	L
RC437CCS	1.875	.50	.50	1.38	1	.25	.44-20	—	.75
RC500CCS	1.875	.50	.50	1.38	1	.25	—	.50-20	.75
RC750CCS	2.500	.75	.75	1.75	1.50	.38	.75-16	—	1

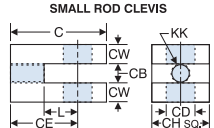

**MATERIAL:** 1018 CRS  
**FINISH:** BLACK OXIDE

**SMALL ROD CLEVIS**

# Accessories: Clevis, Pins & Mounts

ROD CLEVIS								
PART NO.	CB	CD	CE	CH	CW	ER	KK	L
RC437	.75	.50	1.50	1	.50	.50	.44-20	.75
RC500							.50-20	
RC750	1.25	.75	2.38	1.25	.63	.75	.75-16	1.25
RC1000	1.50	1	3.13	1.50	.75	1	1-14	1.50
RC1250	2	1.38	4.13	2	1	1.38	1.25-12	2.13
RC1375	2	1.38	4.13	2	1	1.38	1.38-12	2.13
RC1500	2.50	1.75	4.50	2.38	1.25	1.75	1.50-12	2.25
RC1750	2.50	1.75	4.50	2.38	1.25	1.75	1.75-12	2.25
RC1875	2.50	2	5.50	3	1.25	2	1.88-12	2.50

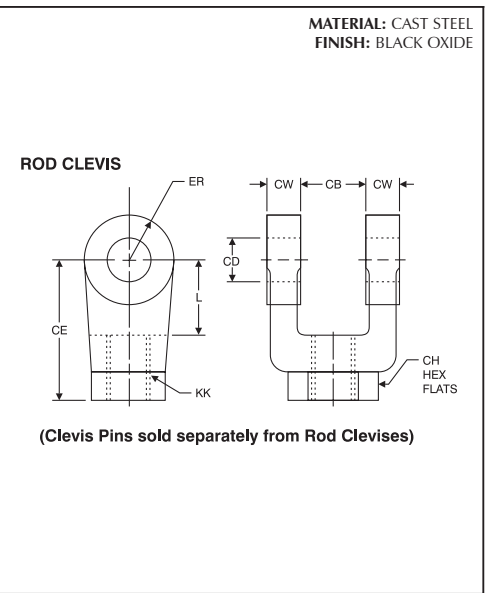

ROD EYE						
PART NO.	A	CA	CB	CD	ER	KK
RE437	.75	1.50	.75	.50	.63	.44-20
RE500						.50-20
RE750	1.13	2.06	1.25	.75	.88	.75-16
RE1000	1.63	2.81	1.50	1	1.19	1-14
RE1250	2	3.44	2	1.38	1.56	1.25-12
RE1500	2.25	4	2.50	1.75	2	1.50-12

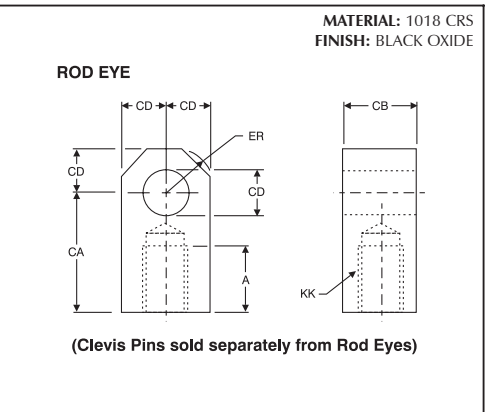

CLEVIS BRACKET										
PART NO.	BA	CB	CD	CW	DD	E	F	FL	L	M
CB500	1.63	.75	.50	.50	.38-24	2.50	.38	1.13	.75	.50
CB750	2.56	1.25	.75	.63	.50-20	3.50	.63	1.88	1.25	.75
CB1000	3.25	1.50	1	.75	.63-18	4.50	.75	2.25	1.50	1
CB1375	3.81	2	1.38	1	.63-18	5	.88	3	2.13	1.38
CB1750	4.94	2.50	1.75	1.25	.88-14	6.50	.88	3.13	2.25	1.75

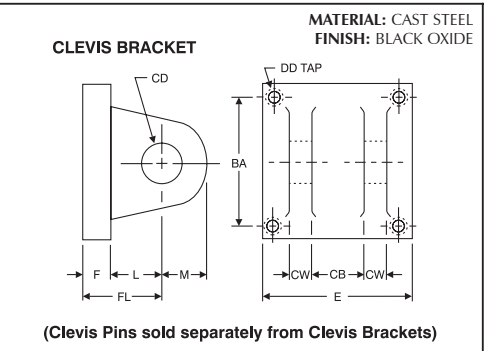

EYE BRACKET										
PART NO.	BA	CB	CD	DD	E	F	FL	L	M	
EB500	1.63	.75	.50	.41	2.50	.38	1.13	.75	.50	
EB750	2.56	1.25	.75	.53	3.50	.63	1.88	1.25	.75	
EB1000	3.25	1.50	1	.66	4.50	.75	2.25	1.50	1	
EB1375	3.81	2	1.38	.66	5	.88	3	2.13	1.38	
EB1750	4.95	2.50	1.75	.91	6.50	.88	3.13	2.25	1.75	

